

# Räumwerkzeughalter für Innenprofile Broaching toolholders for internal profiles

Zylinderschaft / Cyl. shank, VDI DIN 69880  
HSK DIN 69893, ISO 26623, MAS BT

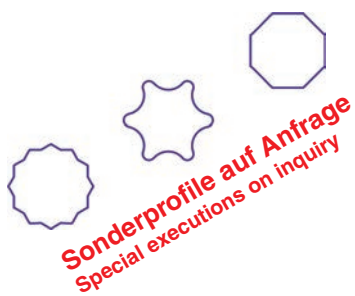

**Katalog Nr. 172**  
**Catalogue No. 172**



## Zur Herstellung von Innenprofilen in selbstschneidender rotierender Bauweise zur Schonung Ihrer Werkzeugmaschine.

Folgende Zuern-Räumwerkzeughalter sind lieferbar:  
Zylinderschaft, VDI - DIN 69880, HSK - DIN 69893 und Polygonalschaft - ISO 26623.

In Standardausführung werden die Räumwerkzeughalter mit zusätzlichen Kühlkanälen direkt zur Schneide geliefert.

Die Räumhalter in schwerer Ausführung müssen alle 40 Betriebsstunden mit 2 Kolbenhüben Spindellagerfett geschmiert werden.

Die Räumstempel sind für eine hohe Standzeit TiN beschichtet.

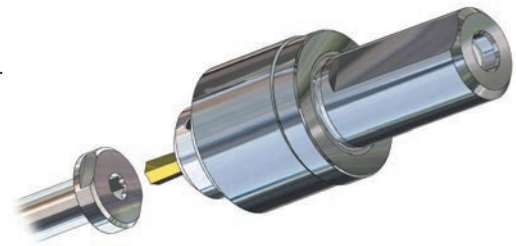

### Empfohlene Anwendung beim Räumen auf CNC-Maschinen:

- Die Bohrung sollte min. das Profilmaß haben, wenn möglich 1% grösser als das Profilmaß.
- Bei Sacklochbohrungen sollte die Bohrungstiefe ca. 1,5 x Profiltiefe sein.
- Die Ansenkung der Bohrung sollte min. dem Außendurchmesser des Profils entsprechen.
- Werkzeugaufnahme im Revolver muss zentrisch stehen - evtl. Kontrolle mit Kontrolldorn !!!
- **Zuern-Räumstempel ø08x28** (evtl. mit Reduzierung 1208.5000) mit Spannschraube im Räumhalter spannen.
- **Zuern-Räumstempel ø12x55** mit Spannschraube im Räumhalter spannen.
- Kühlmittelzufuhr extern oder intern anwählen je nach Maschinentype.
- Der Räumwerkzeughalter mit eingespanntem Räumstempel wird zentrisch im Eilgang vor die vorgearbeitete Bohrung gefahren.
- Die Drehzahl des Werkstückes entspricht etwa der Schnittgeschwindigkeit von HSS-Werkzeugen bei gleichem Werkstoff und Bohrungsdurchmesser, jedoch sollte 2.000 U/min nicht überschritten werden.
- Der Vorschub in Schneidrichtung ist zwischen 0,01 und 0,1 pro Umdrehung zu wählen.
- Der Rückzugsvorschub kann zwischen 0,1 und 0,5 mm pro Umdrehung liegen.
- Bei höheren Drehzahlen kann es von Vorteil sein zuerst mit geringer Drehzahl zu beginnen bis der Räumstempel die Spindeldrehzahl angenommen hat und dann erst auf die volle Drehzahl zu fahren.
- Bei geringer Abnutzung der Schneidkanten kann der Räumstempel stirnseitig bei einem Winkel von 4 - 8° nachgeschliffen werden.

### For efficient production of hexagon or splined profiles in components made from a wide range of materials on CNC lathes and turning centres.

The Zuern range of broaching toolholders are available with the following shank options:  
Cylindrical shank, VDI - DIN 69880, HSK - DIN 69893 and polygonal shank - ISO 26623.

The broaching toolholders are supplied as standard with a through toolholder coolant channel to provide coolant directly to the cutting edge, promoting longer tool life.

The broaching toolholders in heavy execution have to be lubricated with 2 piston strokes of spindle bearing grease every 40 operating hours.

The broaching cutters are TiN coated for a high lifetime.

### Instruction for using the broaching heads & cutters on CNC lathes / turning centres:

- The broaching toolholder must be aligned with the machine centreline and the use of a setting arbor in the machine turret is recommended, prior to mounting the toolholder.
- The component should be drilled and the drill must be a minimum of 1% larger than the across flats dimension of the required hexagon.
- For blind hexagon holes the drilled hole depth must be at least 1.5 x the required length of hexagon section. (This is to allow space for the broached material swarf, to form in the bottom of the blind hole.)
- Clamp the **Zuern-broaching cutter ø08x28mm** (possible with reduction 1208.5000) into the broaching holder using the hexagon screws provided.
- Clamp the **Zuern-broaching cutter ø12x55mm** into the broaching holder using the hexagon screws provided.
- Select via the machine system external or internal coolant, for the use during machining.
- The surface speeds used to broach the components should be based on the speeds when machining the same component material an HSS cutter, but should never exceed 2000 RPM.
- The feed used should be between 0.01 mm and 0.1 mm / revolution. The return feed is to select between 0.1 mm and 0.5 mm / revolution.
- When broaching a new component for the first time it is always advisable to take few test cuts at the lower feeds and speeds and then increase them until a suitable feed and speed is found, enabling efficient and fast production of components.
- Experience has shown that even where upper range of feeds and speeds can be used it is advantageous to commence the broaching operation at a lower speed and feed until the broaching cutter is settled inside the drilled hole and then increase the speed and feed upwards to the selected maximum via the machine control.
- Subject to cutting edge wear the broaching cutter can be reground on the face, at an angle of 4 - 8°.
- Replacement cutters are readily available from the toolholder supplier.

**Allgemeine Verkaufsbedingungen finden Sie auf unserer Website:**

Visit our website for General Condition of Sales:

[www.zuern-tools.de/agb](http://www.zuern-tools.de/agb)

**Räumwerkzeughalter mit Zylinderschaft**  
**Broaching toolholders with cylindrical shank**

Lieferumfang ohne Räumstempel  
Delivery without broaching cutter

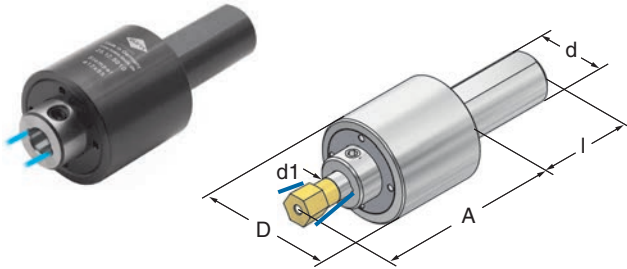

**Reduzierung**  
**Reduction**

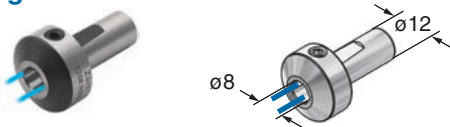

**Räumwerkzeughalter DIN 69880**  
**Broaching toolholders DIN 69880**

Lieferumfang ohne Räumstempel  
Delivery without broaching cutter

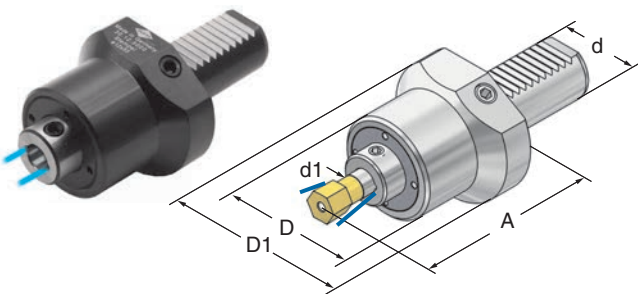

**Reduzierung**  
**Reduction**

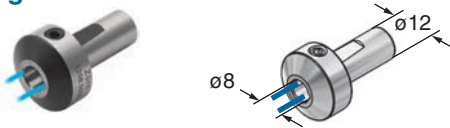

**Zylinderschaft**

Art.-Nr.	Typ	d	d1	l	D	A
16.08.5010	zyl. 16	16	8	38	40	65
20.08.5010	zyl. 20	20	8	38	40	65
22.08.5010	zyl. 22	22	8	48	40	65
25.08.5010	zyl. 25	25	8	48	40	65
22.12.5010	zyl. 22	22	12	55	50	88
25.12.5010	zyl. 25	25	12	55	50	88

**INCH**

1587.08.5010	zyl. 5/8"	15,875	8	38	40	65
1905.08.5010	zyl. 3/4"	19,05	8	38	40	65
2540.08.5010	zyl. 1"	25,4	8	48	40	65
2540.12.5010	zyl. 1"	25,4	12	48	50	88
3175.12.5010	zyl. 1 1/4"	31,75	12	48	50	88

**Schwere Ausführung**  
**Heavy execution**

40.12.5015	zyl. 40	40	12	100	70	121
50.12.5015	zyl. 50	50	12	100	70	121

**Reduzierung**

Art.-Nr.	Typ
1208.5000	Reduzierung / Reduction ø12/ø8

**DIN 69880**

Art.-Nr.	Typ	d	d1	D	D1	A
16.08.5000	VDI 16	16	8	40	44	70
20.08.5000	VDI 20	20	8	40	50	70
25.08.5000	VDI 25	25	8	40	58	70
25.12.5000	VDI 25	25	12	50	58	96
30.12.5000	VDI 30	30	12	50	68	96
40.12.5000	VDI 40	40	12	50	83	96

**Schwere Ausführung**  
**Heavy execution**

40.12.5005	VDI 40	40	12	70	83	121
------------	--------	----	----	----	----	-----

**Reduzierung**

Art.-Nr.	Typ
1208.5000	Reduzierung / Reduction ø12/ø8

## Räumwerkzeughalter DIN 69893 Broaching toolholders DIN 69893

Lieferumfang ohne Räumstempel  
Delivery without broaching cutter

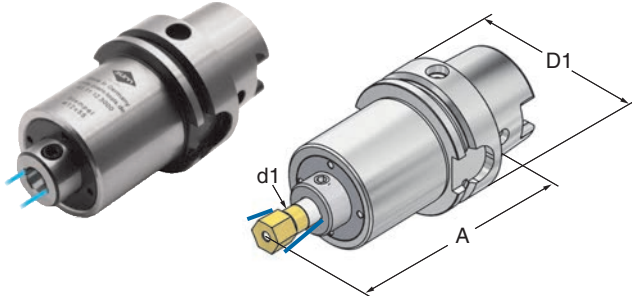

### Reduzierung Reduction

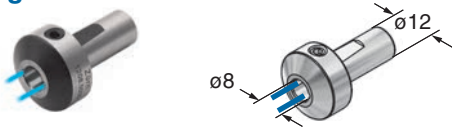

Art.-Nr.	Typ	D1	A	d1
<b>HSK - A40</b>				
40.11.08.5000	HSK-A40x08 x 95	40	95	8
<b>HSK - E 40</b>				
40.12.08.5000	HSK-E40x08 x 95	40	95	8
<b>HSK - C 50</b>				
50.14.12.5000	HSK-C50x12x100	50	100	12
<b>HSK - A 63</b>				
63.11.12.5000	HSK-A63x12x115	63	115	12

### Reduzierung

Art.-Nr.	Typ
1208.5000	Reduzierung / Reduction ø12/ø8

## Räumwerkzeughalter ISO 26623 Broaching toolholders ISO 26623

Lieferumfang ohne Räumstempel  
Delivery without broaching cutter

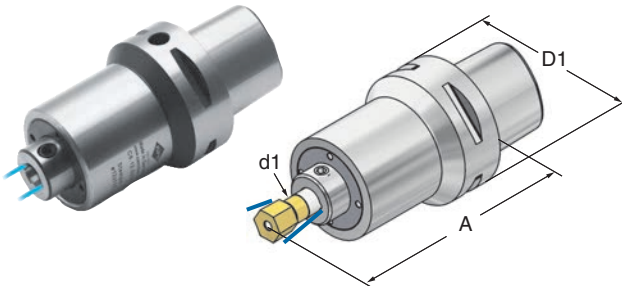

### Reduzierung Reduction

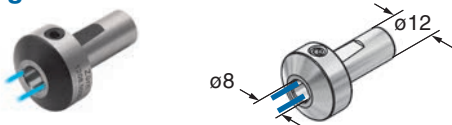

Art.-Nr.	Typ	D1	A	d1
<b>ISO 26623 - C4</b>				
C4.08.5000	C4x08x 80	40	80	8
C4.12.5000	C4x12x103	40	103	12
<b>ISO 26623 - C5</b>				
C5.12.5000	C5x12x100	50	100	12
<b>ISO 26623 - C6</b>				
C6.12.5000	C6x12x115	63	115	12

### Reduzierung

Art.-Nr.	Typ
1208.5000	Reduzierung / Reduction ø12/ø8

## Räumwerkzeughalter MAS BT 15 Broaching toolholders MAS BT 15

Lieferumfang ohne Räumstempel  
Delivery without broaching cutter

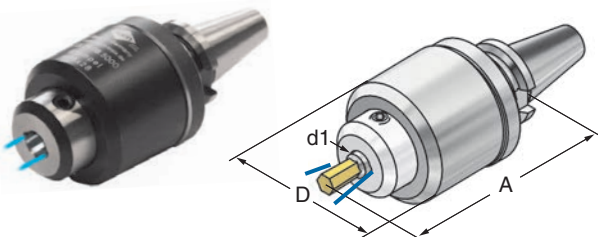

Art.-Nr.	Typ	d1	D	A
<b>MAS BT 15</b>				
15.05.08.5000	BT15x08x78	8	40	78



**Zylinderschaft**

Räumwerkzeughalter für **lageorientierte Kontur**  
**Zylinderschaft - Baugröße 08**  
 Broaching toolholders for **correctly aligned contour**  
 Cylindrical shank - size 08

Lieferumfang ohne Räumstempel  
 Delivery without broaching cutter

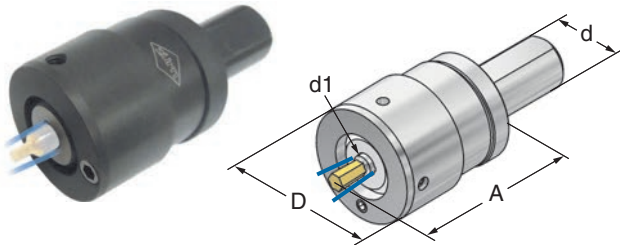

Art.-Nr.	d	d1	D	l	A
16.08.5013	16	8	44	38	65
20.08.5013	20	8	44	38	65
25.08.5013	25	8	44	48	65

**DIN 69880**

Räumwerkzeughalter für **lageorientierte Kontur**  
**DIN 69880 - Baugröße 08**  
 Broaching toolholders for **correctly aligned contour**  
 DIN 69880 - size 08

Lieferumfang ohne Räumstempel  
 Delivery without broaching cutter

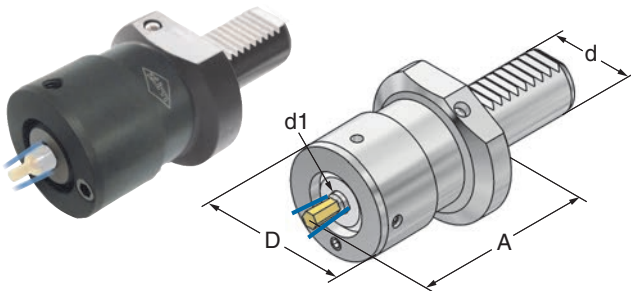

Art.-Nr.	d	d1	D	A
16.08.5003	16	8	44	70
20.08.5003	20	8	44	70
25.08.5003	25	8	44	70

**Anschlag**

Anschlag für **lageorientierte Kontur - Baugröße 12**  
 Stop for **correctly aligned contour - size 12**

Art.-Nr.
2550.5000

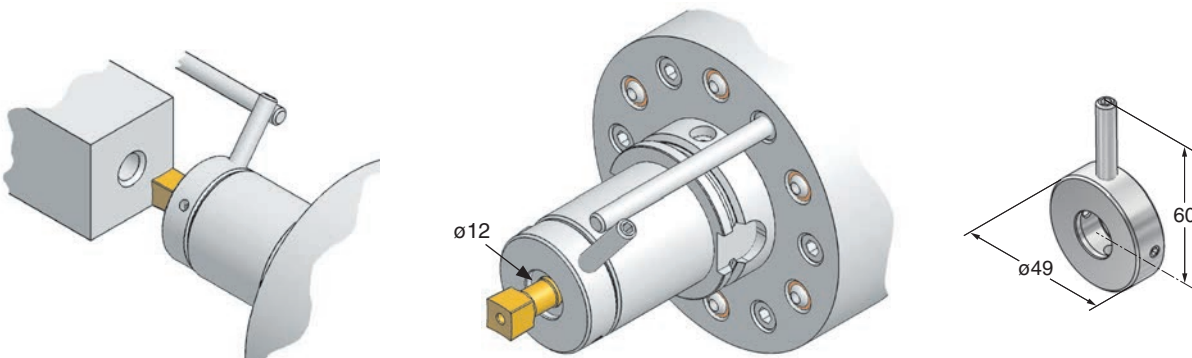

Anschlag beim Werkstück

Anschlag an der Spindel

Sechskant

Räumstempel Sechskant  
Hexagon-broaching cutters

TiN beschichtet  
TiN coated

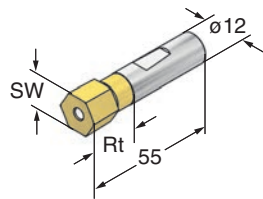
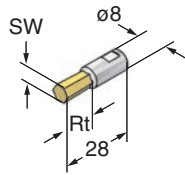

Art.-Nr.	SW	ø	Rt = Räumtiefe
08.015	1,5	8	3
08.020	2	8	4
08.025	2,5	8	4
08.030	3	8	5
08.040	4	8	7
08.050	5	8	9
08.060	6	8	11
08.070	7	8	11
08.080	8	8	11
08.100	10	8	14
12.040	4	12	7
12.050	5	12	9
12.060	6	12	11
12.070	7	12	13
12.080	8	12	15
12.090	9	12	16
12.100	10	12	19
12.110	11	12	19
12.120	12	12	19
12.130	13	12	19
12.140	14	12	24
12.150	15	12	24
12.160	16	12	24
12.170	17	12	24
12.190	19	12	24
12.220	22	12	24

Sechskant INCH

Räumstempel Sechskant INCH  
Hexagon-broaching cutters INCH

TiN beschichtet  
TiN coated

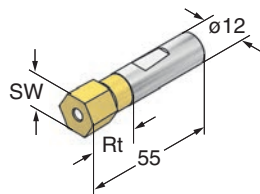
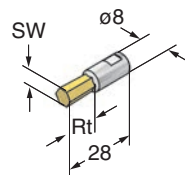

Art.-Nr.	SW INCH	ø	Rt = Räumtiefe
08.5/64	5/64"	8	4
08.3/32	3/32"	8	4
08.7/64	7/64"	8	4
08.1/8	1/8"	8	5
08.9/64	9/64"	8	6
08.3/16	3/16"	8	9
08.7/32	7/32"	8	9
08.1/4	1/4"	8	11
08.5/16	5/16"	8	11
08.3/8	3/8"	8	11
12.1/4	1/4"	12	11
12.3/8	3/8"	12	19
12.7/16	7/16"	12	19
12.1/2	1/2"	12	19

Sonderausführungen auf Anfrage  
Special executions on inquiry



		Vierkant			
		Art.-Nr.	SW □	ø	Rt = Räumtiefe
<b>Räumstempel Vierkant</b> Square-broaching cutters TiN beschichtet TiN coated 		08.4020	2	8	4
		08.4030	3	8	6
		08.4040	4	8	8
		08.4050	5	8	10
		08.4060	6	8	12
		08.4070	7	8	14
		12.4040	4	12	8
		12.4050	5	12	10
		12.4060	6	12	12
		12.4070	7	12	14
	12.4080	8	12	16	
	12.4090	9	12	18	
	12.4100	10	12	20	
		TORX			
		Art.-Nr.	TORX	ø	Rt = Räumtiefe
<b>Räumstempel TORX EN ISO 10664</b> Broaching cutters TORX EN ISO 10664 TiN beschichtet TiN coated 		08.T05	5	8	3
		08.T06	6	8	3
		08.T07	7	8	3
		08.T08	8	8	3
		08.T09	9	8	3
		08.T10	10	8	3
		08.T15	15	8	3
		08.T20	20	8	4
		08.T25	25	8	4
		08.T27	27	8	4
		08.T30	30	8	4
		08.T40	40	8	5
		08.T45	45	8	5
		12.T50	50	12	7
		12.T55	55	12	10
		Kontrolldorn			
		Art.-Nr.	d	l	
<b>Kontrolldorn</b> Control arbor 	08.5000	8	28		
	12.5000	12	55		



**zürn**

## Räumwerkzeughalter für Innenprofile Broaching toolholders for internal profiles

Zylinderschaft / Cyl. shank, VDI DIN 69880  
HSK DIN 69893, ISO 26623, MAS BT

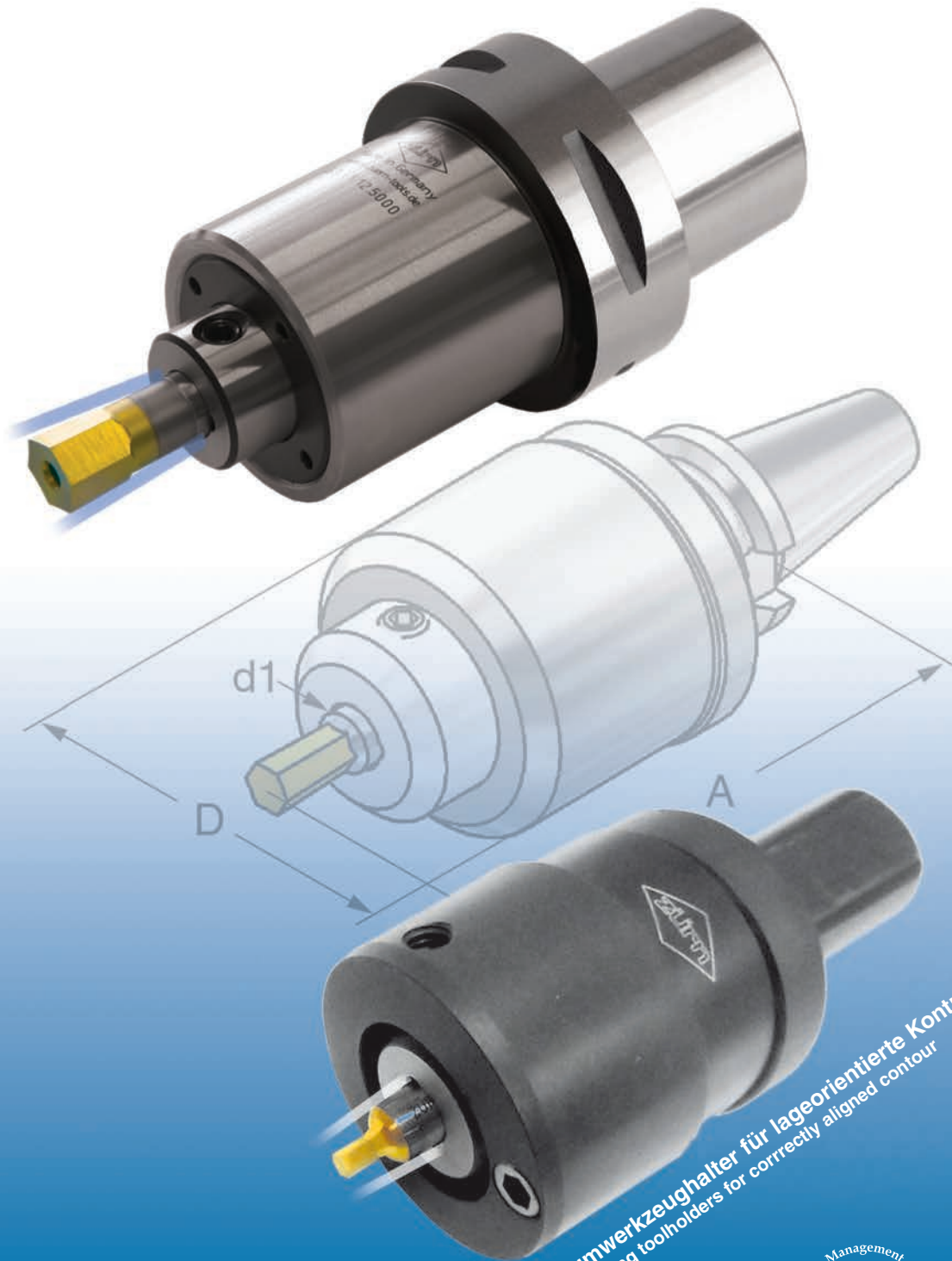

Räumwerkzeughalter für lageorientierte Kontur  
Broaching toolholders for correctly aligned contour

